Driving the next generation of mobile robotics





Vision

We are building the foundations for a smarter world, with intelligent robotics at its core. We enable our **customers to see the possibilities and unlock new opportunities** with flexible automation. In doing so, we aim to make robotics as familiar and useful in the workplace as a laptop or smartphone is today.

Shanghai Robotics

ABB opens state-of-the-art robotics mega factory in Shanghai

New 67,000 m² robotics facility
represents \$150 million investment

Production facility and 'open lab'
customer collaboration center utilizes
digital and automation technologies
to manufacture next generation
robots



Vasteras Robotics

ABB to invest \$280 million in its European Robotics Hub in Sweden

65,000 m² integrated robotics
campus replaces existing site bringing
together automated manufacturing,
R&D, customer experience and
training centers to develop next
generation AI-enabled technologies,
strengthening the company's global
leadership



Auburn Hills Robotics

ABB to expand Robotics factory in US

Investment of \$20 million will increase production at its existing Auburn Hills facility and strengthen ABB US leadership

Newly expanded, highly automated facility will create new jobs in the state of Michigan



A global player

We are close to customers locally, across the value chain

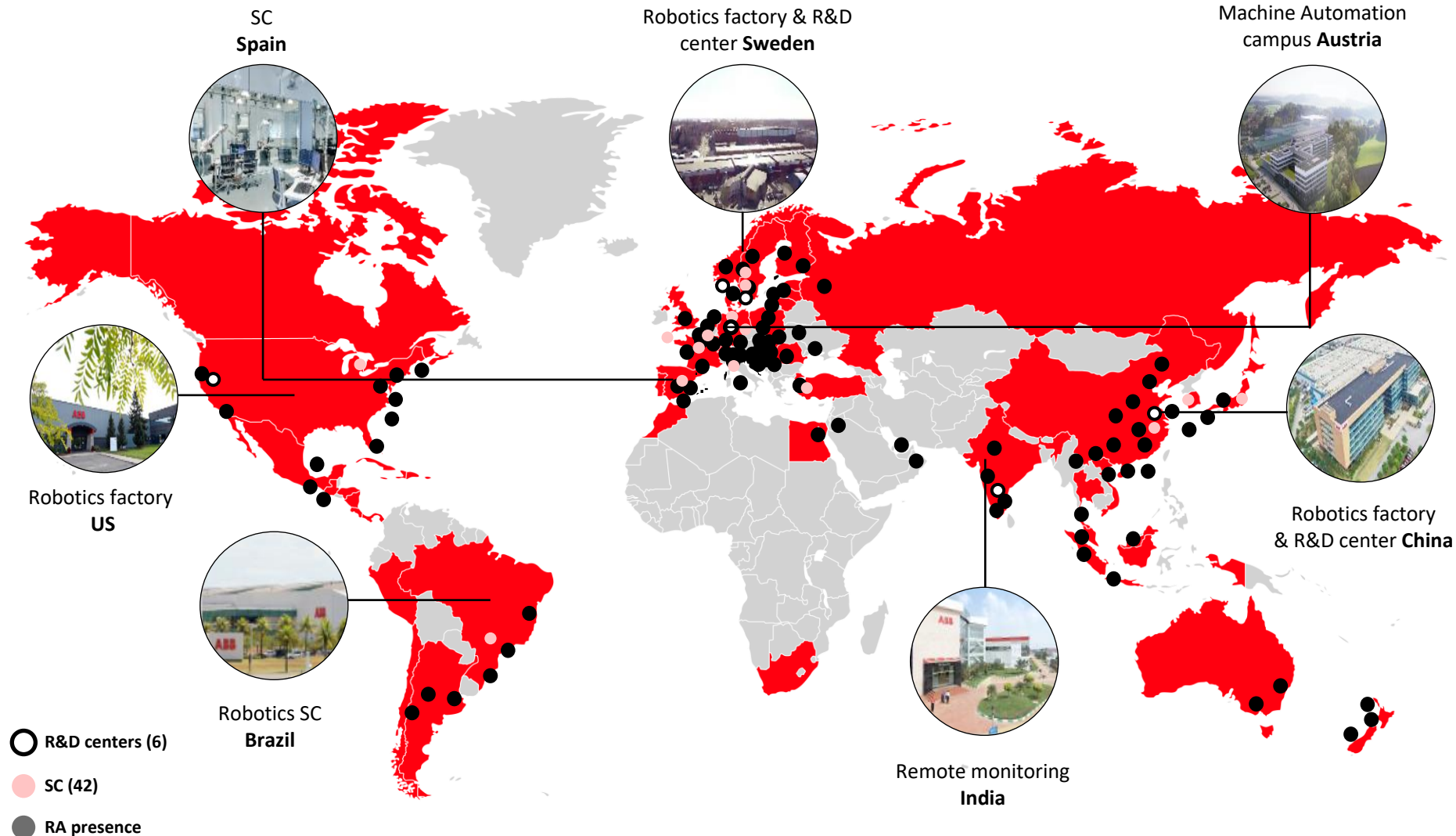

- \$2.9bn** Revenue
- 42** Global Solution centers
- 11,000** Employees
- 1300** Service Experts
- 50+** Countries
- 100+** Locations
-  Global Service & Sales network
-  Unique Authorized Value Provider network

ABB Purpose

We enable a low-carbon society

We reach carbon neutrality in our operations by 2030 and partner with our customers and suppliers to reduce their emissions.

Integrity

We promote social progress

We take care of our people and promote social progress with our partners, suppliers and in communities.

Transparency

We preserve resources

We embed circularity by reducing waste, improving recycling and fostering reusability.



ABB Robotics

GSC AMR



+350 EMPLOYEES



+7000 INSTALLED
AMR



3 GLOBAL SOLUTION
CENTRES

ABB FlexRay Tug
LIMITED

0001

0001

3 Solution Centers (US, ES, CN)
+9 focus markets (CA, MX, BR, UK, SE, DE, CZ, FR, IT)

Production Capacity

Burgos, Spain

Current production capacity
at Burgos factory before
expansion +5000 AMRs/year

Additional production capacity:

01. Shanghai robotic factory
02. Vasteras robotic factory
03. Auburn Hills robotic factory



Burgos Training Center

New training center under construction in Burgos factory

You can choose between several forms of training according to your needs: Teacher-led training, in one of our training centers or on your premises



Driving the next generation of mobile robotics



—

Product solutions

Product portfolio



  Flexley Tug



  Flexley Mover



 Flexley Stack

ABB AMR Portfolio

Flexley Tug 







	AMR T701 	AMR T702 	AMR T901 
	800 N	1600 N	7200 N
	1420 × 500 × 230 mm	2104 × 500 × 230 mm	1424 × 980 × 880 mm
	Magnetic	Magnetic / VSlam	Magnetic / 2D Slam
	Unidirectional	Bidirectional	Unidirectional
	From 0.01 to 1.5 m/s	From 0.01 to 1.5 m/s	From 0.035 to 2 m/s
	Lithium	Lithium	Lithium
	Wi-Fi / RF	Wi-Fi / RF	Wi-Fi / RF

ABB AMR Portfolio

Flexley Mover 

















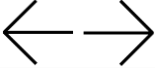
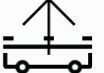

	AMR P304	AMR P404	AMR P603V-1500	AMR P604
				
	600 kg	1.000 kg	1.500 kg	1.500 kg
	1202 × 780 × 352 mm	1202 × 835 × 352 mm	1300 x 850x 300 mm	1940 × 850 × 250 mm
	QR	QR	VSlam	Magnetic / VSlam
	Omnidirectional	Omnidirectional	Bidirectional Differential	Omnidirectional
	120 mm	120 mm	160 mm	180 mm
	From 0.05 to 1.9 m/s	From 0.05 to 1.8 m/s	TBD	From 0.05 to 1.5 m/s
	Lithium	Lithium	Lithium	Lithium
	Wi-Fi	Wi-Fi	Wi-Fi	Wi-Fi / RF

ABB AMR Portfolio

Flexley Stack

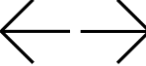
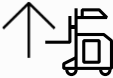

	AMR F602LS	AMR F702LC
		
	1.600 kg	2.000 kg
	2055 x 830 x 2751* mm	2887 x 1172 x 2845* mm
	Laser	Laser
	Bidirectional	Bidirectional
	1800 mm / 4800 mm / 6000 mm	4800 mm / 6000 mm / 8500 mm
	Forward: From 0.03 to 1.7 m/s Backward: From 0.03 to 1 m/s	Forward: From 0.03 to 1.7 m/s Backward: From 0.03 to 1 m/s
	Lithium	Lithium
	Wi-Fi	Wi-Fi

AMR software systems Controls Architecture

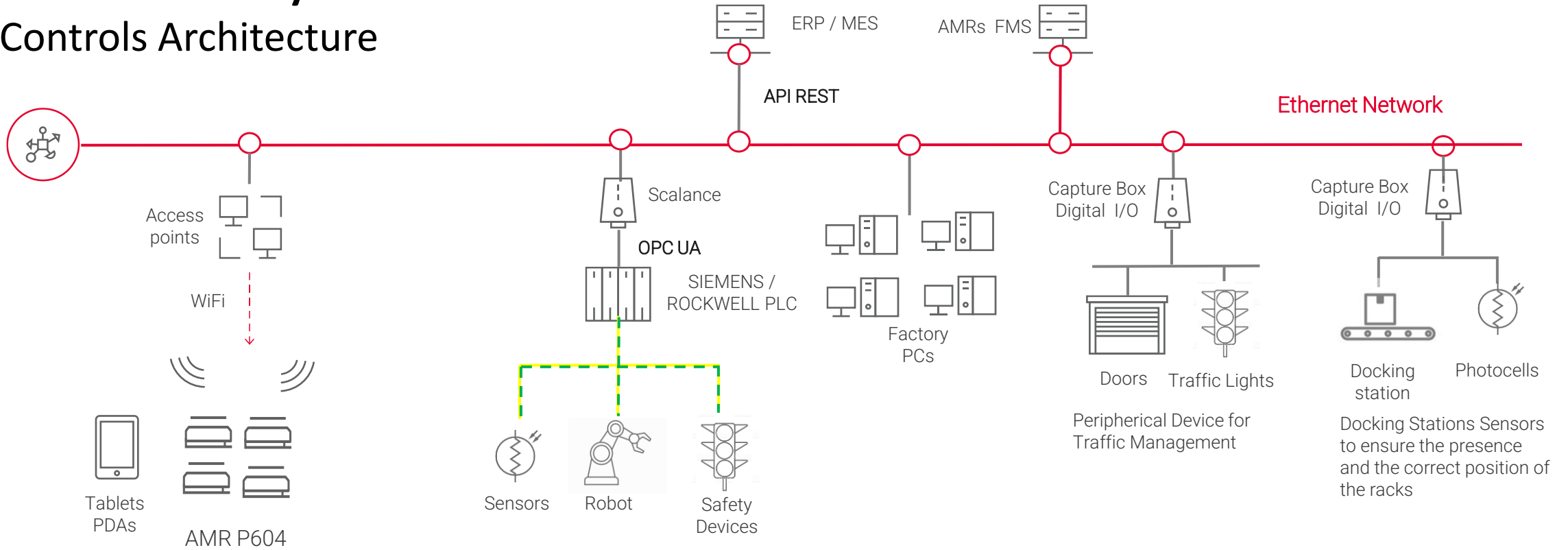

—

VSLAM navigation

Validation Results

High robustness:

- Against dynamic obstacles
- In changing environment
- Against changing light conditions
- Against partial occlusion of cameras

Fleet Repeatability
 ± 5 to ± 10 mm*



Technology Comparison

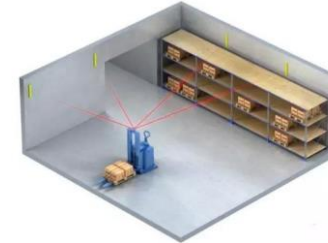
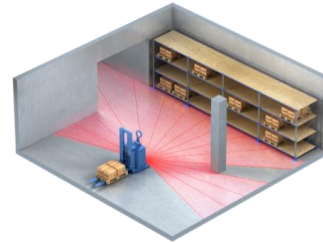
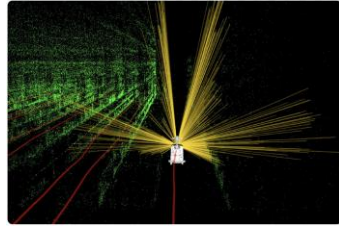

	Visual SLAM	2D SLAM Natural Features	2D LiDAR Reflectors
No additional infrastructure	✓	✓	✗
Fast changing environments	✓	✗	✗
Dynamic and crowded environments	✓	✗	✗
Symmetrical environments	✓	✗	✓
Uneven floor (cracks, ramps..)	✓	✗	✗
Finds position at startup	✓	✗	✓
Enables intelligent features (people and object detection...)	✓	✗	✗
Indoor/Outdoor usage	✓	✗	✗

- ✓ Yes
- ✗ No
- ✗ In certain cases

AMR software systems

AMR Software Suite

ABB | AMR Set up Suite Search...

Welcome to the
ABB revolution

Choose the tool you want to use

All products

LD Layout Designer Draw AMR paths and define the tasks that need to be done through the route.	MM Mission manager Define AMR missions easily using wizard programming.	SC System configuration Configure all the elements within the system.
SM System monitoring Monitor the system and get an overview of its performance,	VD Vehicle diagnostic Monitor vehicle's variables and analyze its logs when needed.	

AMR set up tools

Operation and
monitoring of the AMR
System

AMR software systems

New AMR Studio: Easier Commissioning and Diagnostics Process

BUILDER PACKAGE

Layout Designer

A tool designed to be learned in less than 3 days and with built-in intelligence to guide users through the whole process.

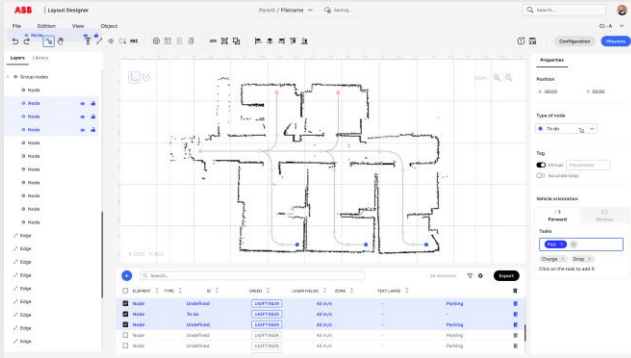

Tool used to map the environment and draw the path that AMRs will follow and to set up all traffic rules.

Mission manager

No-code tool to allow users to program the behavior of the AMR Fleet without any programming skills

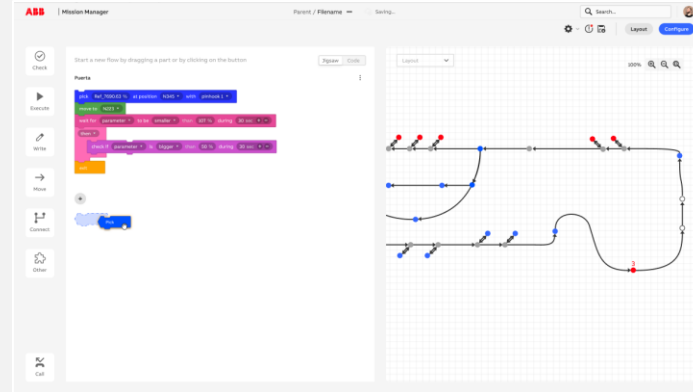

Tool used to define all missions and Jobs that AMRs need to carry out in the system. It can work connected to the Fleet Manager or directly to the vehicle, in case we have a small system without Fleet Manager.

CONTROL FLEET PACKAGE

Fleet Manager

It includes a web-based tool to keep the AMR system under control

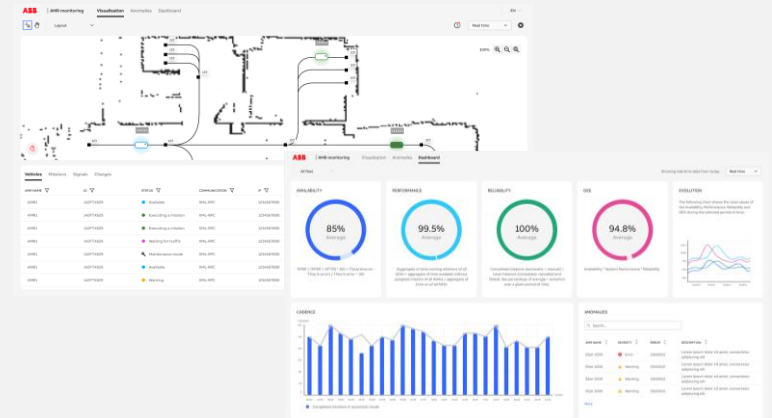

User can see the AMRs moving through the layout, check anomalies and order tracking. Plant managers can measure their automation system's benefits by checking the main KPIs in performance. The fleet manager will take care of assigning the optimal AMRs to each mission.

Driving the next generation of mobile robotics



—

Applications

—

Customer Examples AMR Solutions

Driving the next generation of mobile robotics

